



## Experiencing problems with your new KidKraft product?

Before getting frustrated and returning your product to the store or Internet retailer, please give us a chance to solve all your problems. Call our office in **Dallas, TX** at **1-800-933-0771**. Our sales support team is available from **8:30 a.m. to 5 p.m.** Central Time Zone every **Monday through Friday**, and we want nothing more than for our customers to be satisfied. If you have a question and it isn't our normal business hours, just leave a message and we will call you back as soon as possible. Don't want to talk to someone? Information on replacement parts can be found at [www.kidkraft.com](http://www.kidkraft.com).

- Are our assembly instructions confusing? Are you stuck on a step?

**Please, let us help!**

- Are you missing a part? Do you need us to send a replacement part?

**Please, let us help!**

- Did a part arrive broken? Do you need us to send a replacement?

**Please, let us help!**

- Does the item you received differ in any way from what was ordered?

**Please, let us help!**

At KidKraft, customer satisfaction is our top priority. Thank you for your business.

David Barr  
Executive Vice President

KidKraft  
4630 Olin Road  
Dallas Texas 75244  
[www.kidkraft.com](http://www.kidkraft.com)  
Toll Free: 1.800.933.0771  
Tel: 972.385.0100  
Fax: 972.385.0277

Before calling customer service, please  
have your item's batch code ready.  
This is your batch code:

If your batch code is not listed here,  
you can find it on the back or bottom  
of your product.  
(example batch code:101287/65006A/04)

# 2-in-1 Activity Table with Board Compatible with Lego® Products

Item# 17576, 17577

Please retain this information for future reference

## Assembly Instructions

To order replacement parts, please visit [www.kidkraft.com](http://www.kidkraft.com)

### HARDWARE:

A. Cross Dowel Bolt  
x 8 pcs



2 1/4 in / 58 mm

B. Cross Dowel Nut  
x 8 pcs



Allen Wrench x 1 pc

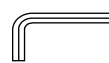

The following  
tool (not included)  
is required for  
assembly:



Flathead screwdriver

### PARTS LIST:

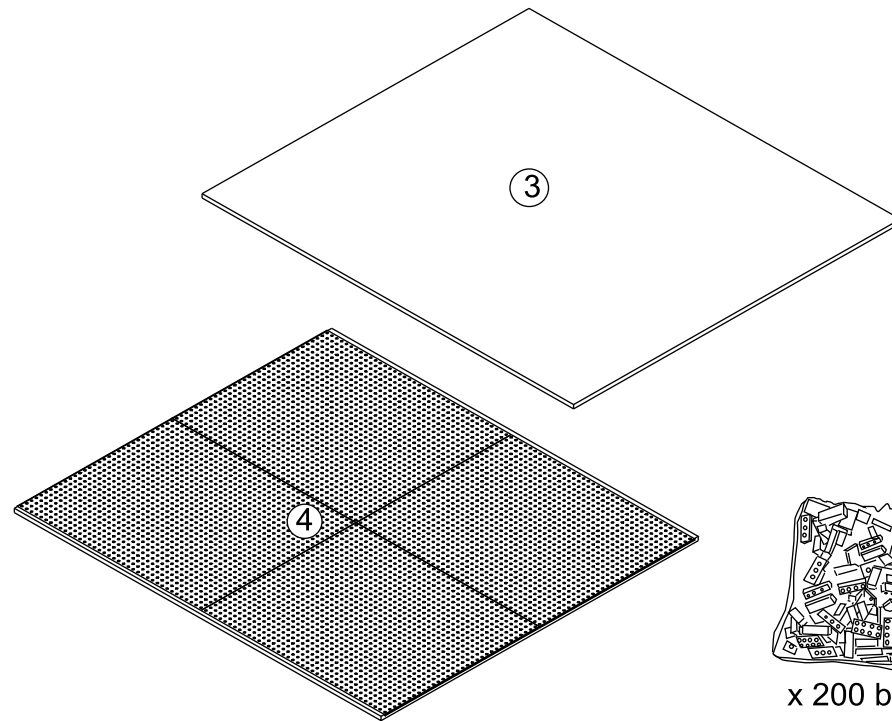
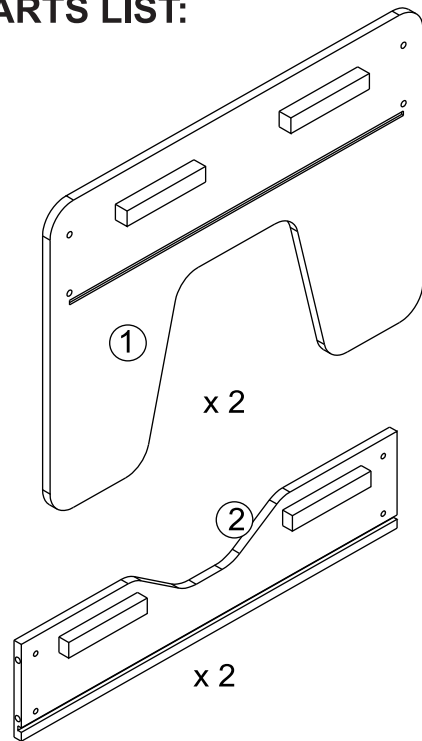

### Step 1

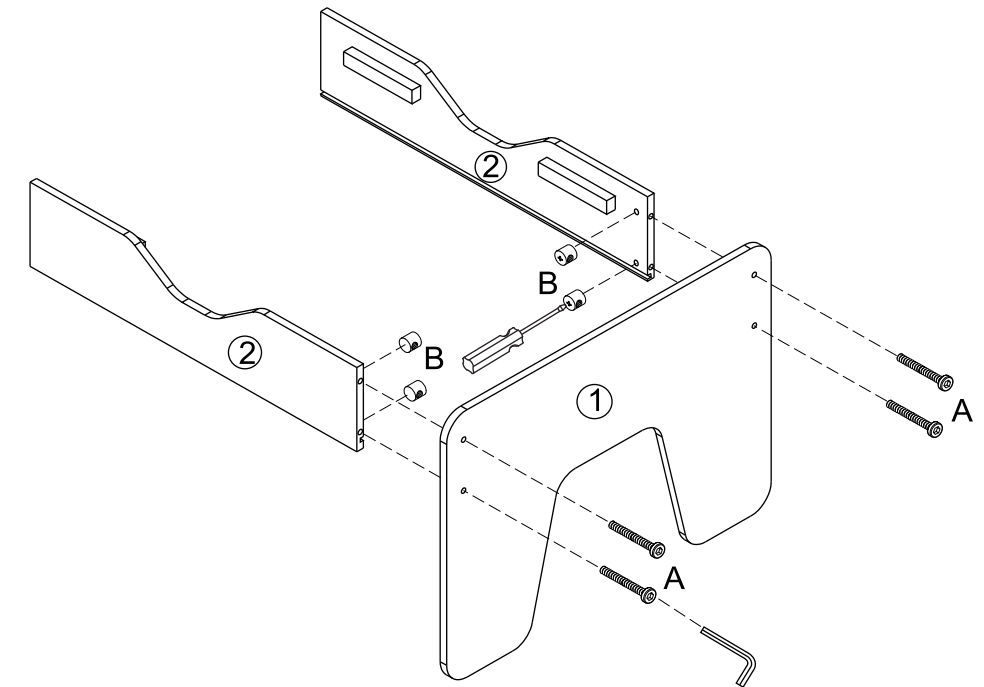

### Step 2

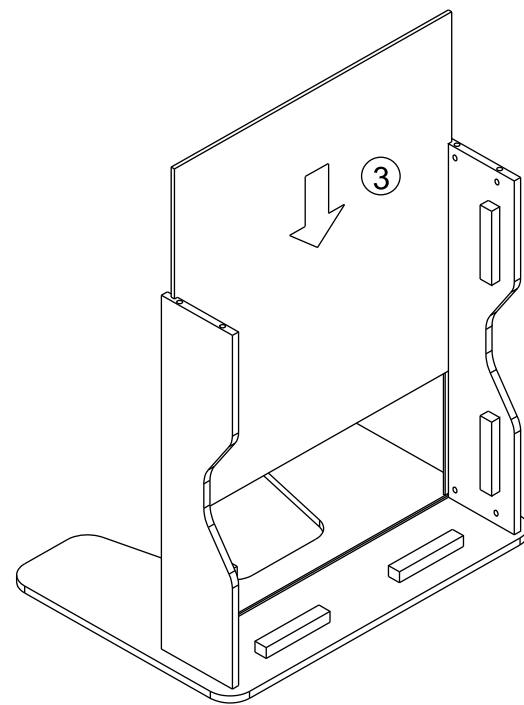

### Step 3

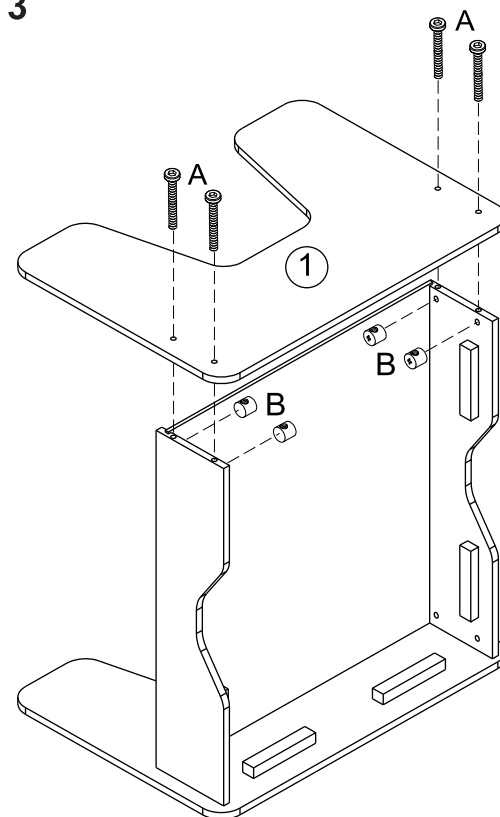

### Step 4

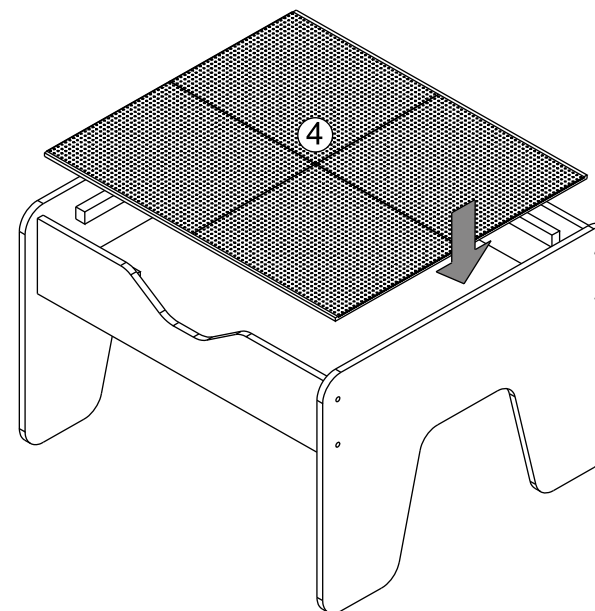

### Step 5

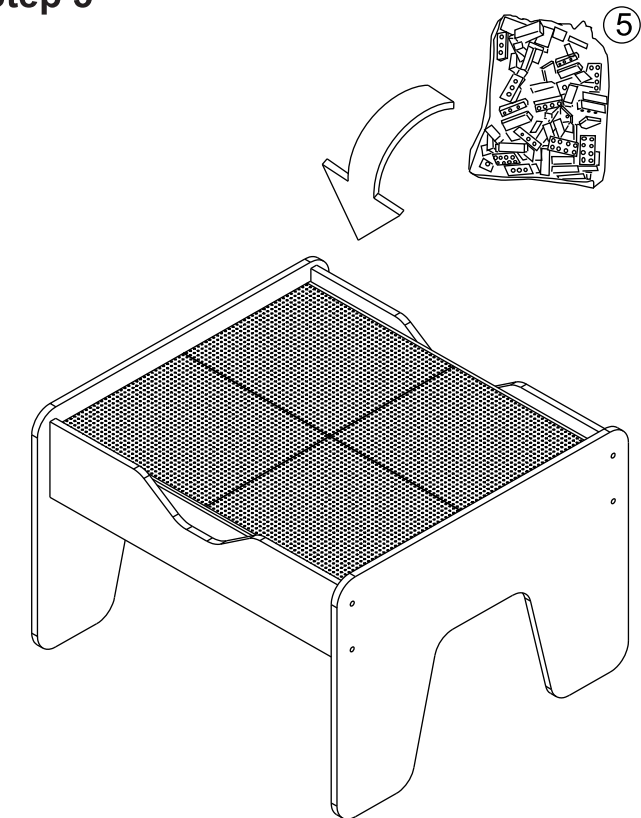

**CAUTION:**  
ADULT ASSEMBLY REQUIRED. Hardware contains small screws with sharp points. Keep unassembled parts out of the reach of small children.

**USE AND MAINTENANCE:**  
-Use on level surfaces only  
-Please check assembly at regular intervals, and frequently tighten hardware if necessary. If maintenance is not carried out, the product could cease to function properly.

**WARNING:**  
CHOKING HAZARD - Small parts, not for children under 3 years.







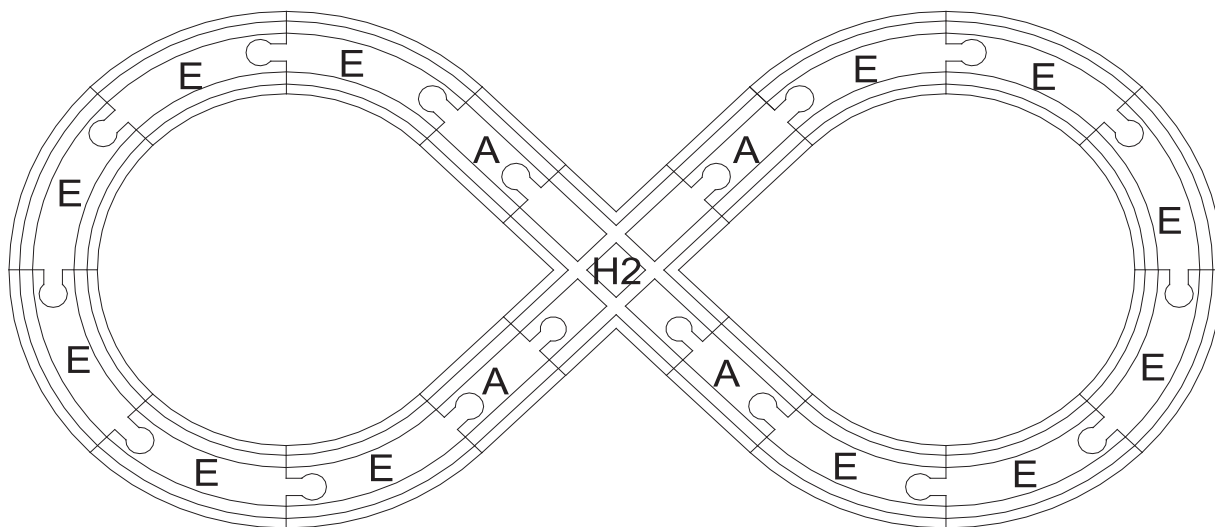

# 2-in-1 Activity Table with Board Compatible with Lego® Products

## Assembly Instructions

Item # 17576

### TRACK LAYOUT:

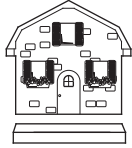
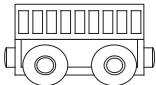
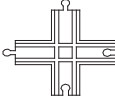

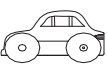
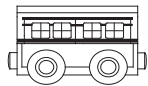
A	 x 4	150	 x 1	141 B	 x 1	750	 x 1
E	 x 12	102	 x 3	350	 x 1 x 1 = 2	850	 x 1
H2	 = 1	141 O	 x 1	501 A	 x 1	851	 x 1

Before calling customer service, please locate the batch code number (example: 2693/65006/04) found on the bottom or back of your product.

**Customer Service**  
**1-800-933-0771**  
**www.kidkraft.com**

**Warning: This is intended for children of a specific age or above. Keep children younger than the specified age from using this item. Do not let children of any age climb on or around this item. Adult supervision is always recommended.**



**WARNING!** This product contains small magnets that can be hazardous if swallowed. Seek immediate medical attention if magnet(s) are swallowed or inhaled.

## **IMPORTANT INFORMATION - PLEASE READ FIRST**

ALL OF OUR WOODEN ITEMS ARE HANDCRAFTED, HAND ASSEMBLED, AND HAND PAINTED. EACH ONE IS UNIQUE. SLIGHT IMPERFECTIONS MAY OCCUR AND ARE NOT MANUFACTURING DEFECTS.

PLEASE NOTE THAT WE DO NOT WARRANTY AGAINST THE USE OF PERMANENT MARKERS, NON-WATER-BASED PAINTS, CRAYONS, OR WASHABLE MARKERS. SOME OF THESE ITEMS CONTAIN PERMANENT COLOR DYES THAT COULD DAMAGE THE SURFACE.

## **CLEANING INSTRUCTIONS**

CLEAN THE SURFACE USING A SLIGHTLY DAMP CLOTH AND MILD DISH WASHING LIQUID IF NECESSARY. DO NOT USE ANY CLEANING PRODUCT CONTAINING ALCOHOL OR AMMONIA. THESE WILL DULL THE SHINY SURFACE OF THE PRODUCT. FURNITURE POLISH WILL ALSO WORK TO CLEAN AND DUST OFF THE SURFACE.

WE RECOMMEND THAT YOU TEST ALL CLEANING MATERIALS ON THE UNDERSIDE OF ANY SURFACE THAT WOULD NOT BE SEEN DURING NORMAL USE OF THE PRODUCT. IF YOU HAVE QUESTIONS REGARDING THE MAINTENANCE OF THIS PRODUCT PLEASE FEEL FREE TO CALL US.

## **SOLE AND LIMITED WARRANTY**

THIS PRODUCT IS WARRANTED SOLELY AGAINST MANUFACTURING DEFECTS FOR A PERIOD OF 90 DAYS FROM THE DATE OF PURCHASE, WHICH RUNS ONLY TO THE ORIGINAL USER OF THE PRODUCT. IN THE EVENT OF A MANUFACTURING DEFECT, PARTS WILL BE REPLACED OR THE ENTIRE PRODUCT WILL BE REPLACED OR THE PURCHASE PRICE WILL BE REFUNDED, AT THE ELECTION OF THE MANUFACTURER. TO ACTIVATE AND PROTECT THIS WARRANTY, PRESERVE EVIDENCE OF ORIGINAL PURCHASE AND CAREFULLY INSPECT THE CONDITION OF THE PRODUCT PRIOR TO AND AFTER ASSEMBLY, LOOKING FOR MISSING, DEGRADED, BROKEN, IMPROPERLY SIZED OR HAZARDOUS PARTS, INCLUDING PARTS WHICH CAN BE SWALLOWED BY A CHILD, CAUSE A CHILD TO CHOKE, OR OTHERWISE CAUSE INJURY. SUCH PARTS MAY INCLUDE LOOSE SCREWS, EXPOSED NAILS OR SHARP EDGES. SHOULD YOU OBSERVE ANY DEFECTS, DO NOT USE THE PRODUCT AND IMMEDIATELY NOTIFY THE MANUFACTURER. FAILURE TO DO SO SHALL CONSTITUTE MISUSE. MISUSE, IMPROPER ASSEMBLY, FAILURE TO HONOR A WARNING, FAILURE TO SUPERVISE, INSPECT OR MAINTAIN THE PRODUCT, OR DAMAGE TO THE PRODUCT, WHETHER INTENTIONAL OR INADVERTENT, SHALL INVALIDATE THIS WARRANTY. THIS WARRANTY GIVES YOU SPECIFIC LEGAL RIGHTS, AND YOU MAY ALSO HAVE OTHER RIGHTS WHICH VARY FROM STATE TO STATE.

TO SUBMIT A WARRANTY CLAIM PLEASE CONTACT KIDKRAFT CUSTOMER SERVICE AT 1-800-933-0771 FOR INSTRUCTIONS ON HOW TO PROVIDE PROOF OF PURCHASE AND HOW TO RETURN THE ITEM FREIGHT PRE-PAID.

**CUSTOMER SERVICE 1-800-933-0771**

## **IMPORTANT INFORMATION - PLEASE READ FIRST**

THIS TOY IS INTENDED FOR THE ENJOYMENT AND DEVELOPMENT OF CHILDREN BETWEEN THE AGES OF 3 AND 8. IT HAS BEEN SPECIFICALLY DESIGNED AND TESTED FOR USE BY CHILDREN OF THAT AGE RANGE IN A CONSTRUCTIVE SETTING. BECAUSE OF THE DANGER OF SMALL PARTS BECOMING A CHOKING HAZARD FOR TODDLERS, DO NOT BUY YOUR 2-YEAR-OLD A TOY MEANT FOR CHILDREN AGES 3 AND ABOVE. PARENTAL SUPERVISION AND INSPECTION IS ALWAYS REQUIRED TO PREVENT INJURY AND MISUSE OR DEGRADATION OF THE TOY, REGARDLESS OF THE AGE OF THE CHILD. USE OF THE TOY BY PERSONS OTHER THAN CHILDREN OF THE INTENDED AGE MAY RESULT IN INJURY TO THE USER OR BYSTANDER OR BREAKAGE OF THE TOY. CONTINUED PARENTAL SUPERVISION AND INSPECTION IS VITAL TO THE SAFE USE OF THE TOY AS SMALL PARTS MAY BREAK OFF OR COME LOOSE OVER TIME AND DURING USE, AND SHARP EDGES MAY RESULT FROM MISUSE, HEAVY USE, AGE OF THE TOY, OR THE ENVIRONMENT, INCLUDING RECURRING HEAT, COLD AND WATER. TO SAFEGUARD THE CHILD AND PROLONG THE SAFE LIFE OF THE TOY, FOLLOW THE ENCLOSED ASSEMBLY AND MAINTENANCE INSTRUCTIONS CAREFULLY AND HONOR ALL WARNINGS. INSPECT FOR LOOSE AND BROKEN PARTS FREQUENTLY. SHOULD YOU HAVE ANY QUESTIONS OR CONCERNS, CONTACT KIDKRAFT CUSTOMER SERVICE AT 1-800-933-0771. REPLACEMENT PARTS MAY BE AVAILABLE FREE OF CHARGE.

## **CLEANING INSTRUCTIONS**

CLEAN THE SURFACE USING A SLIGHTLY DAMP CLOTH AND MILD DISH WASHING LIQUID IF NECESSARY. DO NOT USE ANY CLEANING PRODUCT CONTAINING ALCOHOL OR AMMONIA. THESE WILL DULL THE SHINY SURFACE OF THE PRODUCT. FURNITURE POLISH WILL ALSO WORK TO CLEAN AND DUST OFF THE SURFACE.

WE RECOMMEND THAT YOU TEST ALL CLEANING MATERIALS ON THE UNDERSIDE OF ANY SURFACE THAT WOULD NOT BE SEEN DURING NORMAL USE OF THE PRODUCT. IF YOU HAVE QUESTIONS REGARDING THE MAINTENANCE OF THIS PRODUCT PLEASE FEEL FREE TO CALL US.

## **SOLE AND LIMITED WARRANTY**

THIS TOY IS WARRANTED SOLELY AGAINST MANUFACTURING DEFECTS FOR A PERIOD OF 90 DAYS THE DATE OF PURCHASE, WHICH RUNS ONLY TO THE ORIGINAL USER OF THE TOY. IN THE EVENT OF A MANUFACTURING DEFECT, PARTS WILL BE REPLACED OR THE ENTIRE PRODUCT WILL BE REPLACED OR THE PURCHASE PRICE WILL BE REFUNDED, AT THE ELECTION OF THE MANUFACTURER.

TO ACTIVATE AND PROTECT THIS WARRANTY, PRESERVE EVIDENCE OF ORIGINAL PURCHASE AND CAREFULLY INSPECT THE CONDITION OF THE TOY PRIOR TO AND AFTER ASSEMBLY, LOOKING FOR MISSING, DEGRADED, BROKEN OR HAZARDOUS PARTS, INCLUDING PARTS WHICH CAN BE SWALLOWED BY A CHILD, CAUSE A CHILD TO CHOKE, OR OTHERWISE CAUSE INJURY. SUCH PARTS MAY INCLUDE MAGNETS, WHEELS, HUBS, FASTENERS, AND CONNECTORS. SHOULD YOU OBSERVE ANY DEFECTS, DO NOT USE THE TOY AND IMMEDIATELY NOTIFY THE MANUFACTURER. FAILURE TO DO SO SHALL CONSTITUTE MISUSE. MISUSE, IMPROPER ASSEMBLY, FAILURE TO HONOR A WARNING, FAILURE TO SUPERVISE, INSPECT OR MAINTAIN THE TOY, OR DAMAGE TO THE TOY, WHETHER INTENTIONAL OR INADVERTENT, SHALL INVALIDATE THIS WARRANTY. THIS WARRANTY GIVES YOU SPECIFIC LEGAL RIGHTS, AND YOU MAY ALSO HAVE OTHER RIGHTS WHICH VARY FROM STATE TO STATE.

TO SUBMIT A WARRANTY CLAIM PLEASE CONTACT KIDKRAFT CUSTOMER SERVICE AT 1-800-933-0771 FOR INSTRUCTIONS ON HOW TO PROVIDE PROOF OF PURCHASE AND HOW TO RETURN THE ITEM FREIGHT PRE-PAID.

**CUSTOMER SERVICE 1-800-933-0771**