



Experiencing problems with your new KidKraft product?

Before getting frustrated and returning your product to the store or Internet retailer, please give us a chance to solve all your problems. Call our office in **Dallas, TX** at **1-800-933-0771**. Our sales support team is available from **8:30 a.m. to 5 p.m.** Central Time Zone every **Monday through Friday**, and we want nothing more than for our customers to be satisfied. If you have a question and it isn't our normal business hours, just leave a message and we will call you back as soon as possible. Don't want to talk to someone? Information on replacement parts can be found at www.kidkraft.com.

- Are our assembly instructions confusing? Are you stuck on a step?

Please, let us help!

- Are you missing a part? Do you need us to send a replacement part?

Please, let us help!

- Did a part arrive broken? Do you need us to send a replacement?

Please, let us help!

- Does the item you received differ in any way from what was ordered?

Please, let us help!

At KidKraft, customer satisfaction is our top priority. Thank you for your business.

David Barr
Executive Vice President

KidKraft
4630 Olin Road
Dallas Texas 75244
www.kidkraft.com

Before calling customer service, please locate the batch code number (example: 2693/65006/04) found on the bottom or back of your product.

Tel: 972.385.0100
Toll Free: 1.800.933.0771
Fax: 972.385.0277
Toll Free: 1.877.933.0771





5 x 5 Sandbox

Assembly Instructions

Item #00130A

Please retain this information for future reference

To order replacement parts, please visit www.kidkraft.com

- HARDWARE:**
- A. Cross Dowel Bolt x 8 pcs

(2 1/2 in, 63 mm)
 - B. Cross Dowel Bolt x 32 pcs

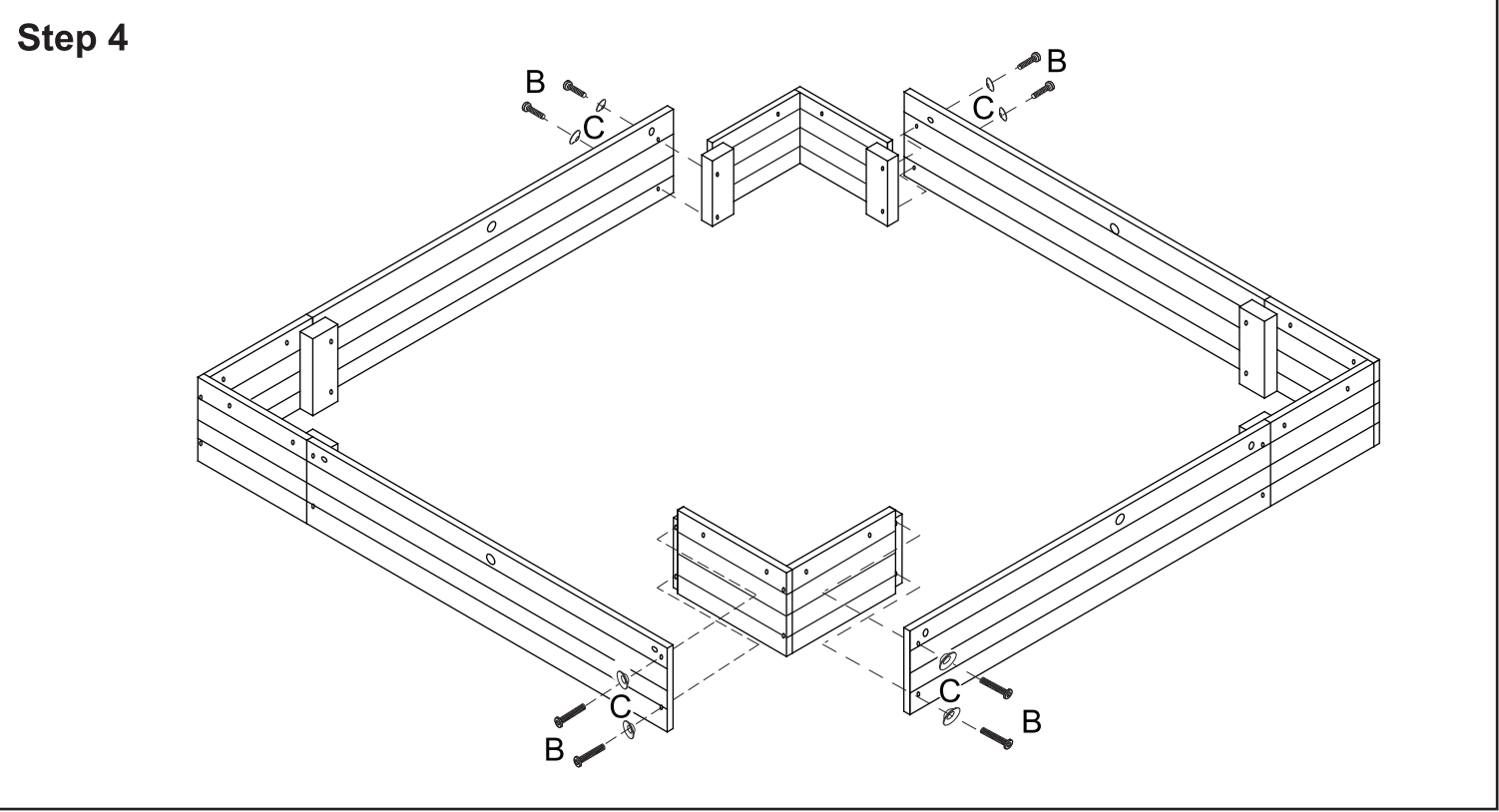
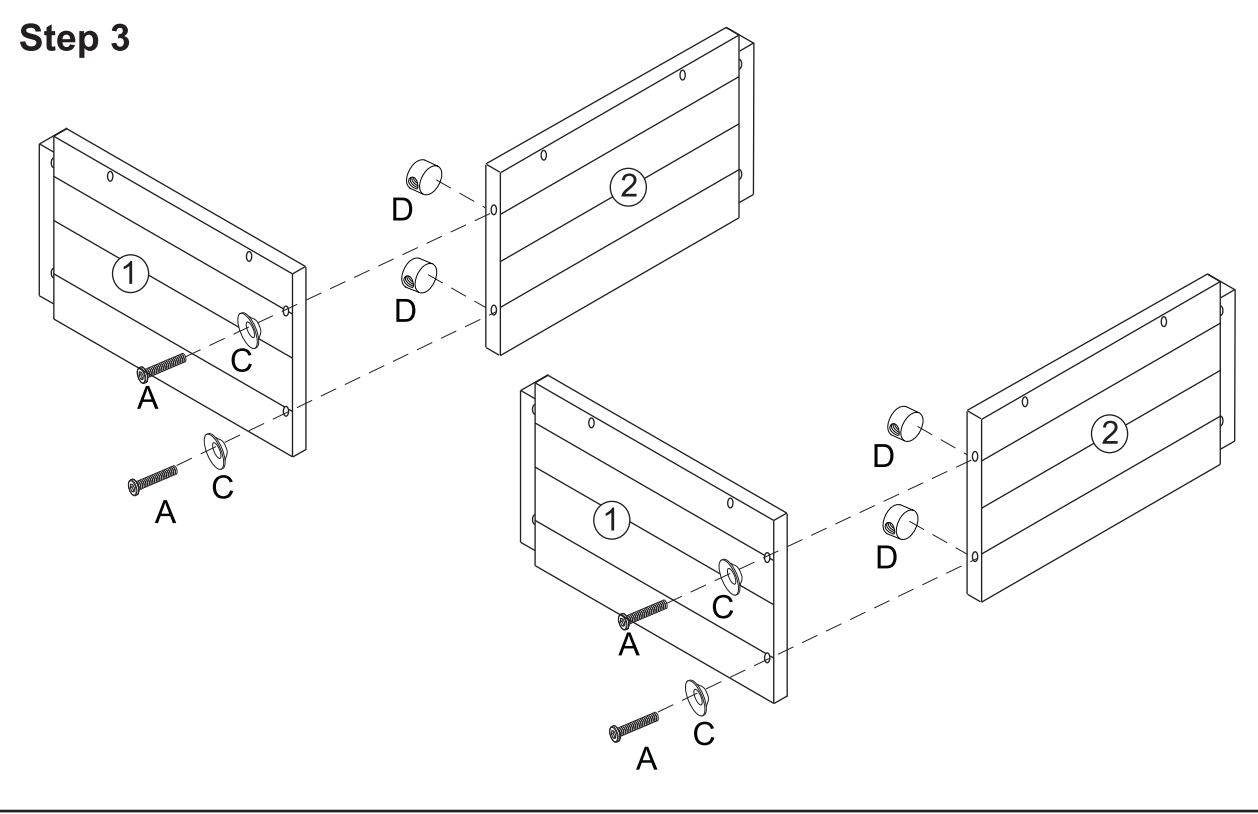
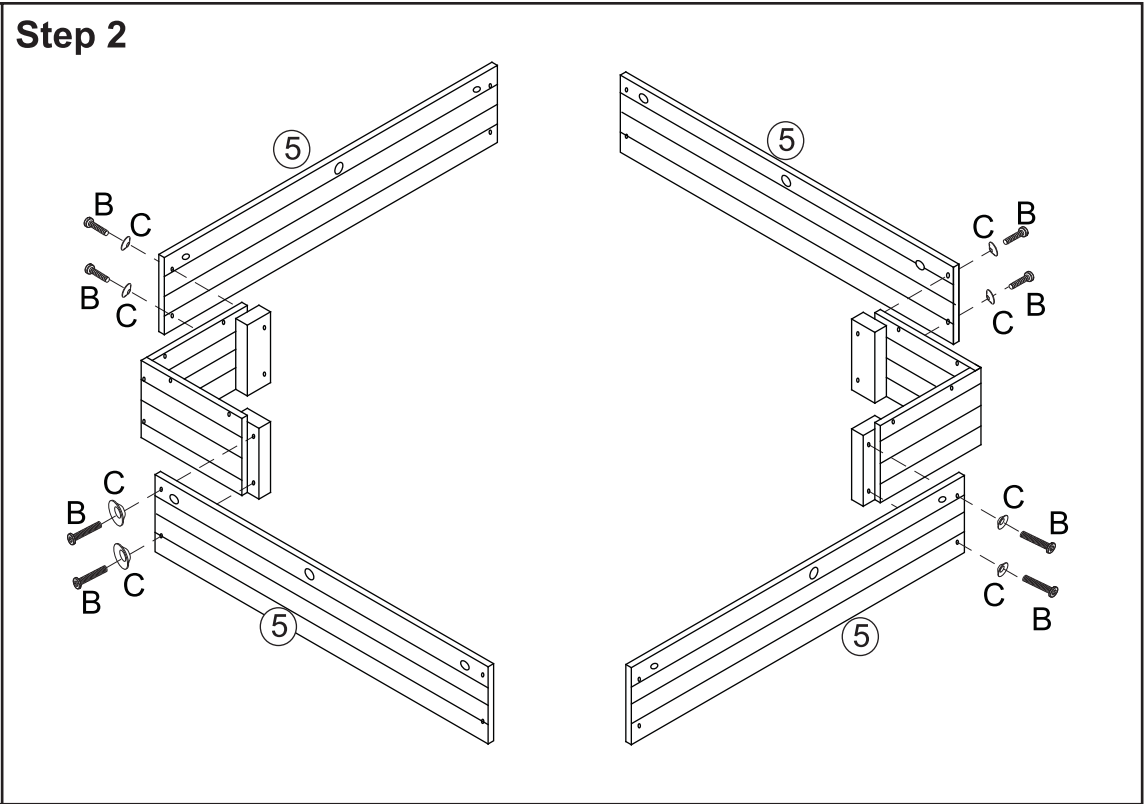
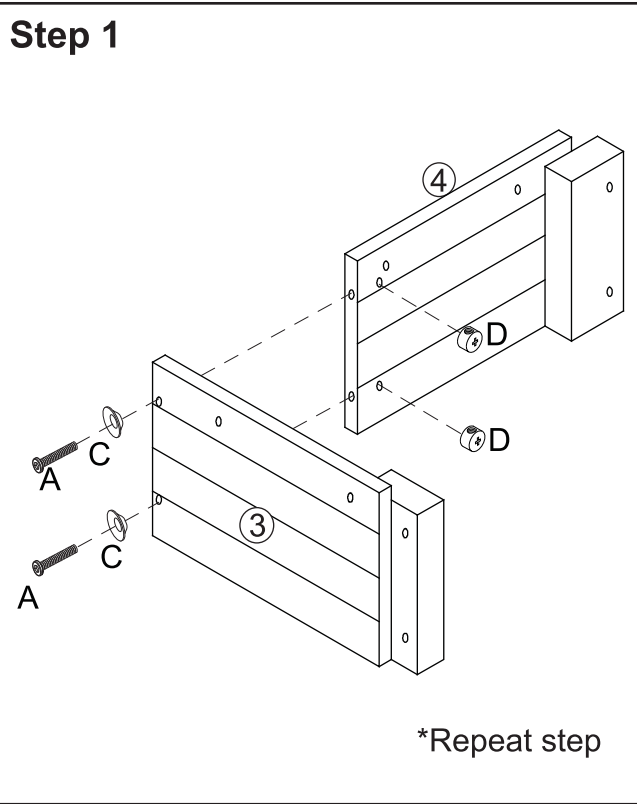
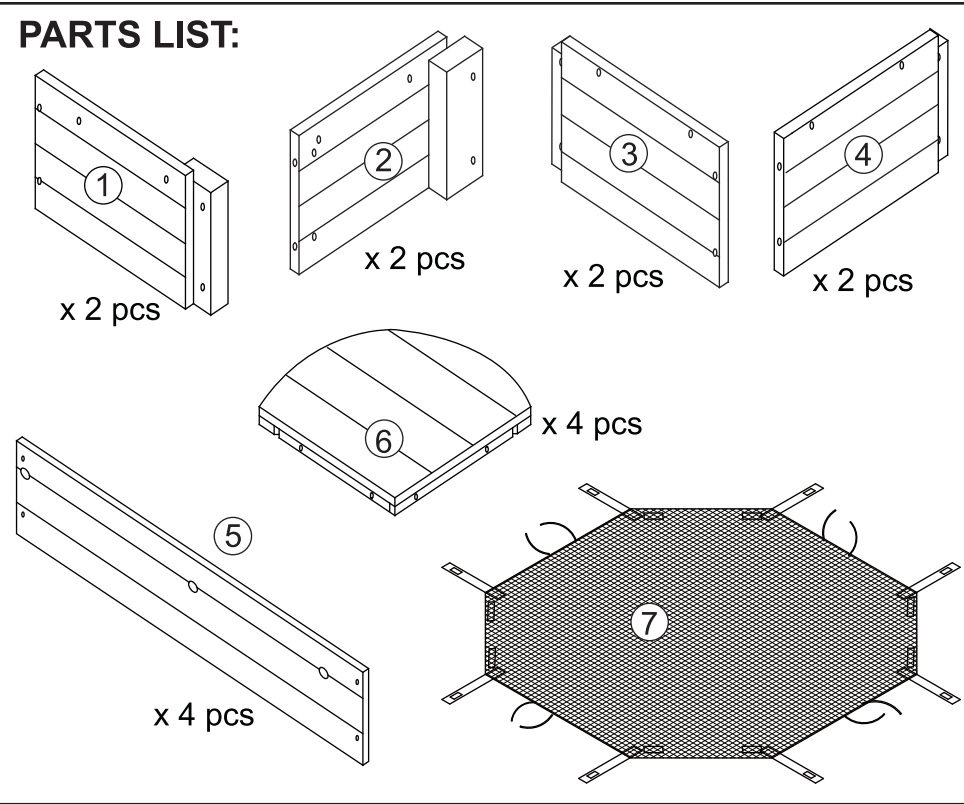
(1 11/16 in, 43 mm)
 - C. Countersunk Washer x 40 pcs

 - D. Cross Dowel Nut x 8 pcs

Allen Wrench
x 1 pc

CAUTION:
ADULT ASSEMBLY REQUIRED. Hardware contains small screws with sharp points. Keep unassembled parts out of the reach of small children.

USE AND MAINTENANCE:

- Use on level surfaces only
- Please check assembly at regular intervals, and frequently tighten hardware if necessary. If maintenance is not carried out, the product could cease to function properly.

WARNING:
CHOKING HAZARD. Small parts and sharp points, not suitable for children under 3 years.

Customer Service
1-800-933-0771
www.kidkraft.com

5 x 5 Sandbox

Assembly Instructions

Item #00130A

Please retain this information for future reference

To order replacement parts, please visit www.kidkraft.com

Step 5

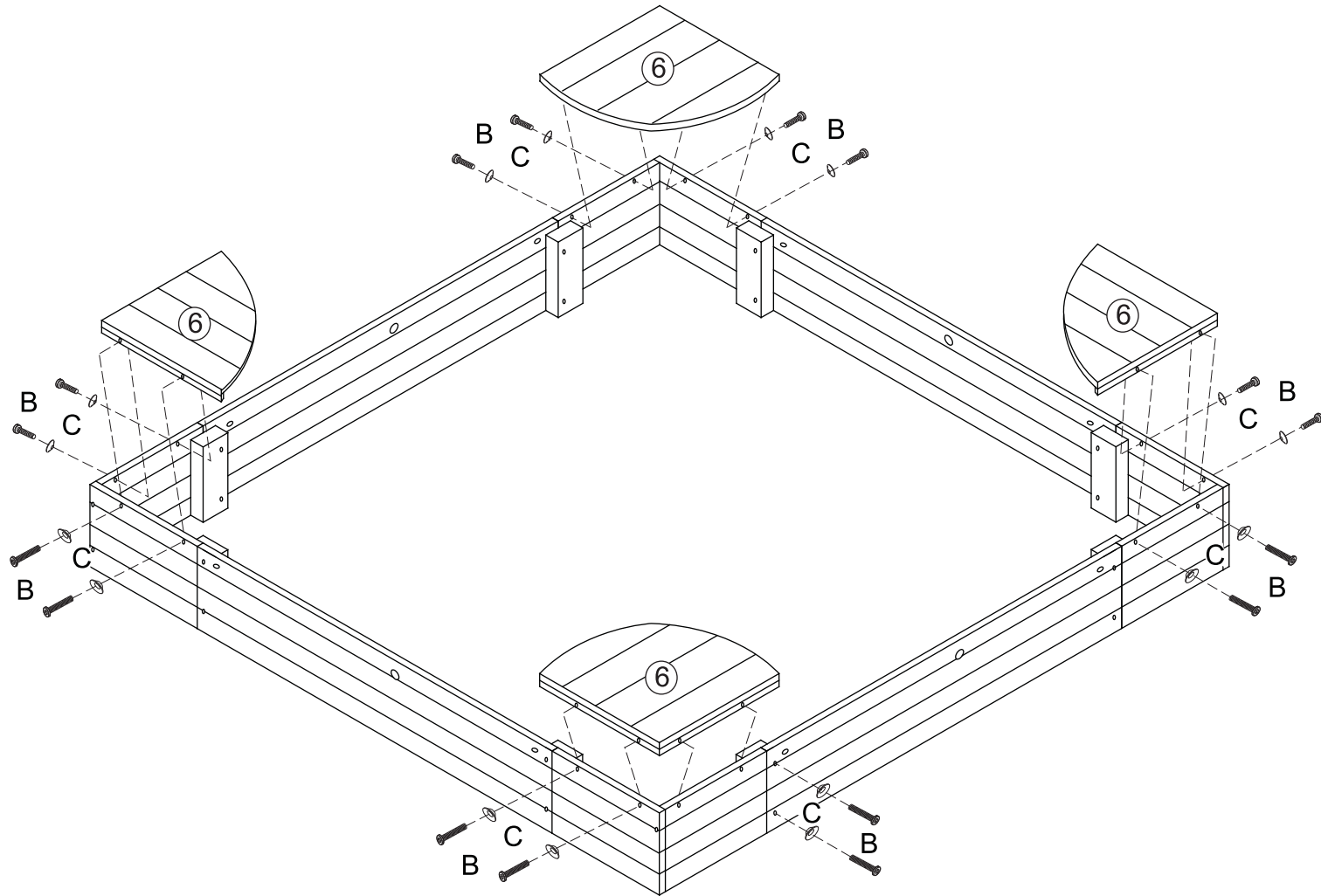

Step 6

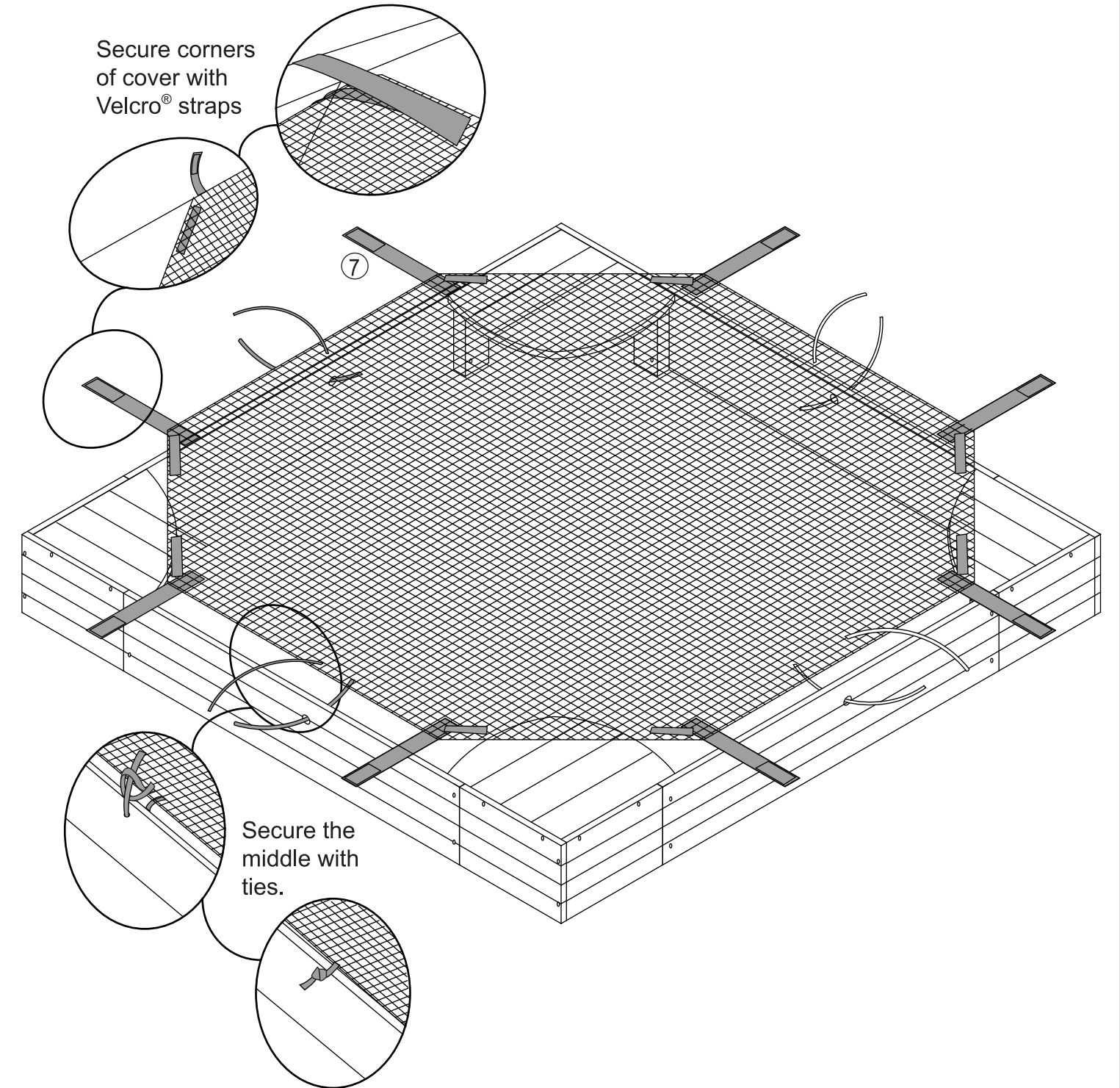

Before calling customer service, please locate the batch code number (example: 2693/65006/04) found on the bottom or back of your product.

Customer Service
1-800-933-0771
www.kidkraft.com



IMPORTANT SAFETY NOTICE

THIS PRODUCT IS INTENDED FOR THE USE AND ENJOYMENT OF CHILDREN AGES 3 AND UP. IT HAS BEEN SPECIFICALLY DESIGNED AND TESTED FOR USE BY CHILDREN OF THAT AGE RANGE. PARENTAL SUPERVISION AND INSPECTION IS ALWAYS REQUIRED TO PREVENT INJURY AND MISUSE OR DEGRADATION OF THE PRODUCT, REGARDLESS OF THE AGE OF THE CHILD. USE OF THE PRODUCT BY PERSONS OTHER THAN CHILDREN OF THE INTENDED AGE MAY RESULT IN INJURY TO THE USER OR BYSTANDER OR BREAKAGE OF THE SANDBOAT. CONTINUED PARENTAL SUPERVISION AND INSPECTION IS VITAL TO THE SAFE USE OF THE PRODUCT AS PARTS MAY BREAK OFF OR COME LOOSE OVER TIME AND DURING USE, AND SHARP EDGES MAY RESULT FROM MISUSE, HEAVY USE, AGE OF THE PRODUCT, OR THE ENVIRONMENT, INCLUDING RECURRING HEAT, COLD AND WATER. TO SAFEGUARD THE CHILD AND PROLONG THE SAFE LIFE OF THE PRODUCT, FOLLOW THE ENCLOSED ASSEMBLY AND MAINTENANCE INSTRUCTIONS CAREFULLY AND HONOR ALL WARNINGS. INSPECT FOR LOOSE, UNSTABLE, SHARP AND BROKEN PARTS FREQUENTLY. DO NOT PERMIT CHILDREN TO CLIMB OR JUMP OFF UNIT. SHOULD YOU HAVE ANY QUESTIONS OR CONCERNS, CONTACT KIDKRAFT CUSTOMER SERVICE AT 1-800-933-0771. REPLACEMENT PARTS MAY BE AVAILABLE FREE OF CHARGE.

MAINTENANCE

THIS IS AN OUTDOOR WOOD PRODUCT THAT NATURALLY WEATHERS WITH AGE. TO ENSURE OPTIMAL, LONG-TERM DURABILITY AND FUN, TREATMENT WITH AN OIL-BASED OUTDOOR WOOD SEALER IS REQUIRED. WOOD SEALER CAN BE PURCHASED AT YOUR LOCAL HARDWARE STORE, AND SHOULD BE APPLIED AT FIRST SIGNS OF WEATHERING.

IF YOU HAVE ANY QUESTIONS REGARDING MAINTENANCE AND CARE OF YOUR PRODUCT, PLEASE FEEL FREE TO CALL US AT 1-800-933-0771.

TO PROLONG THE LIFE OF YOUR OUTDOOR ITEM, PLEASE STORE OUT OF DIRECT SUNLIGHT OR EXPOSURE TO EXTREME WEATHER.

SOLE AND LIMITED WARRANTY

THIS PRODUCT IS WARRANTED SOLELY AGAINST MANUFACTURING DEFECTS FOR A PERIOD OF 90 DAYS FROM THE DATE OF PURCHASE, WHICH WARRANTY RUNS ONLY TO THE ORIGINAL USER OF THE PRODUCT. IN THE EVENT OF A MANUFACTURING DEFECT, THE PRODUCT WILL BE REPLACED OR THE PURCHASE PRICE REFUNDED, AT THE ELECTION OF THE MANUFACTURER. TO ACTIVATE AND PROTECT THIS WARRANTY, PRESERVE EVIDENCE OF ORIGINAL PURCHASE AND CAREFULLY INSPECT THE CONDITION OF THE PRODUCT PRIOR TO AND AFTER ASSEMBLY, LOOKING FOR MISSING, DEGRADED, BROKEN, IMPROPERLY SIZED OR HAZARDOUS PARTS, INCLUDING PARTS WHICH CAN BE SWALLOWED BY A CHILD, CAUSE A CHILD TO CHOKe, OR OTHERWISE CAUSE INJURY. SUCH PARTS MAY INCLUDE LOOSE SCREWS, EXPOSED NAILS OR SHARP EDGES. SHOULD YOU OBSERVE ANY DEFECTS, DO NOT USE THE PRODUCT AND IMMEDIATELY NOTIFY THE MANUFACTURER. FAILURE TO DO SO SHALL CONSTITUTE MISUSE. MISUSE, IMPROPER ASSEMBLY, FAILURE TO HONOR A WARNING, FAILURE TO SUPERVISE, INSPECT OR MAINTAIN THE PRODUCT, OR DAMAGE TO THE PRODUCT, WHETHER INTENTIONAL OR INADVERTENT, SHALL INVALIDATE THIS WARRANTY.

TO SUBMIT A WARRANTY CLAIM PLEASE CONTACT KIDKRAFT CUSTOMER SERVICE AT 1-800-933-0771 FOR INSTRUCTIONS ON HOW TO PROVIDE PROOF OF PURCHASE AND HOW TO RETURN THE ITEM FREIGHT PRE-PAID.

CUSTOMER SERVICE 1-800-933-0771

www.kidkraft.com